

80459

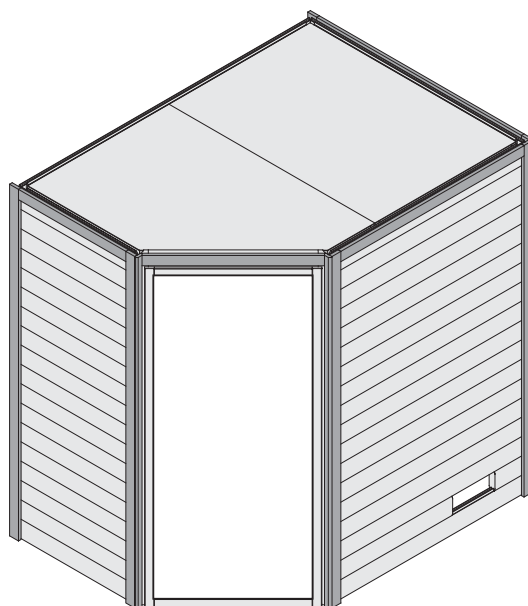

-  **Aufbauanleitung**
-  **Building Instructions**
-  **notice de montage**
-  **montagehandleiding**
-  **Montagevejledning**
-  **Instrucciones de construcción**
-  **Istruzioni per il montaggio**
-  **Montážní návod**

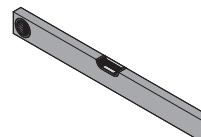

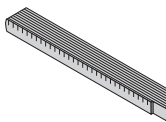
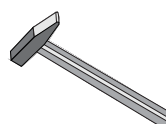
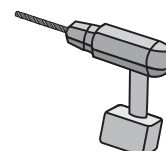
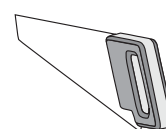

Vergleichen Sie zuerst die Material-liste mit Ihrem Paketinhalt! Bitte haben Sie Verständnis, dass Beanstandungen nur im nicht aufgebauten Zustand bearbeitet werden können!



Vergelijk eerst de lijst van materialen met de inhoud van uw pakket! Reclamaties kunnen alleen in behandeling worden genomen zolang de onderdelen nog niet zijn gemonteerd!



Confrontate questa distinta materiali prima con il contenuto del pacchetto! Vi preghiamo di comprendere che eventuali reclami possono essere accolti solo prima del montaggio!



First compare the list of materials with your package contents! Please understand that complaints can be processed in the non-built status only!



Start med at kontrollere materialelisten med indholdet af den leverede pakke! Vi gør venligst opmærksom på at reklamationer kun kan behandles for materialer som ikke er blevet bearbejdet!



Nejprve přezkontrolujte obsah balení podle materiálového listu! Mějte pochopení pro to, že případnou reklamaci se můžeme zabývat pouze tehdy, když díly nebudou smontované! Za pomoci tohoto seznamu můžete jednotlivé díly přiřadit k montážnímu návodu.



Commencez par comparer la liste du matériel avec le contenu de votre paquet! Sachez que nous traitons uniquement les réclamations concernant le matériel à l'état non monté!



En primer lugar, compare la lista de material con el contenido del paquete. Rogamos entienda que las reclamaciones sólo pueden ser tramitadas antes de montar el objeto!

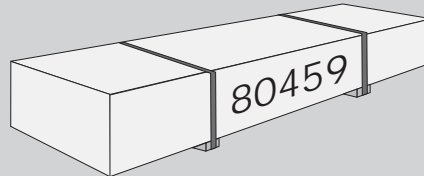

1 x B1	1920 x 20 x 3 mm	ID 20799	
2 x B2	1810 x 90 x 16 mm	ID 71513	
1 x B3	850 x 58 x 17 mm	ID 48544	
7 x B4	2000 x 58 x 17 mm	ID 48541	
2 x B5	250 x 45 x 18 mm	ID 26716	
2 x B6	550 x 45 x 18 mm	ID 26717	
2 x B7	800 x 45 x 18 mm	ID 24796	
1 x B8	880 x 45 x 18 mm	ID 21440	
2 x B9	1206 x 45 x 18 mm	ID 21439	
2 x B10	1809 x 45 x 18 mm	ID 21831	
1 x B11	300 x 95 x 18 mm	ID 19130	
4 x B12	480 x 95 x 18 mm	ID 20930	
4 x B13	565 x 95 x 18 mm	ID 15498	
2 x B14	800 x 58 x 28 mm	ID 15493	
3 x B15	1916 x 36 x 36 mm	ID 21431	
1 x B16	781 x 78 x 38 mm	ID 56718	

2 x C1	1916 x 36 x 36 mm	ID 21814	
2 x C2	1973 x 36 x 36 mm	ID 21825	

2 x G1	2100 x 40 x 18 mm	ID 80276	

2 x G2	2000 x 58 x 17 mm	ID 48545	

1 x R1	1338 x 918 x 55 mm	ID 26585	

1 x R2	1338 x 918 x 55 mm	ID 26575	

1 x W1	803 x 121 x 38 mm	ID 80496	

1 x W2	200 x 121 x 38 mm	ID 80382	

18 x W3	777 x 121 x 38 mm	ID 26726	
17 x W4	1278 x 121 x 38 mm	ID 21430	
18 x W5	1380 x 121 x 38 mm	ID 26573	
17 x W6	1881 x 121 x 38 mm	ID 21429	

1 x W7	1881 x 121 x 38 mm	ID 21864	

1 x E1	1820 x 140 x 26 mm	ID 26480	

1 x L1	1810 x 250 x 90 mm	ID 26576	
1 x L2	1810 x 550 x 90 mm	ID 43994	

2 x L3	250 x 45 x 45 mm	ID 3863	
2 x L4	555 x 45 x 45 mm	ID 40301	

1 x		ID 14025	



- Siehe Türpaket
- Opmerking Door Package
- Note Door Package
- Remarque Package porte
- Nota Paquete Puerta
- Nota Door Package
- Poznámka Door balíček



1 x D1

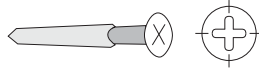

20 x	4 x 30 mm	ID 3686
60 x	4 x 35 mm	ID 3687
350 x	4 x 40 mm	ID 21925
30 x	4 x 50 mm	ID 3688
30 x	4 x 70 mm	ID 3689
25 x	4,5 x 80 mm	ID 9204
20 x	6 x 60 mm	ID 14014
20 x	6 x 80 mm	ID 47558
80 x	6 x 90 mm	ID 26715

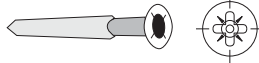

50 x	4,5 x 40 mm	ID 26285
------	-------------	----------



60 x		ID 26116
------	--	----------



6 x	3 x 16mm	ID 46376
-----	----------	----------

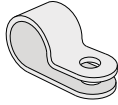

1 x		ID 50420
-----	--	----------

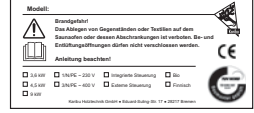





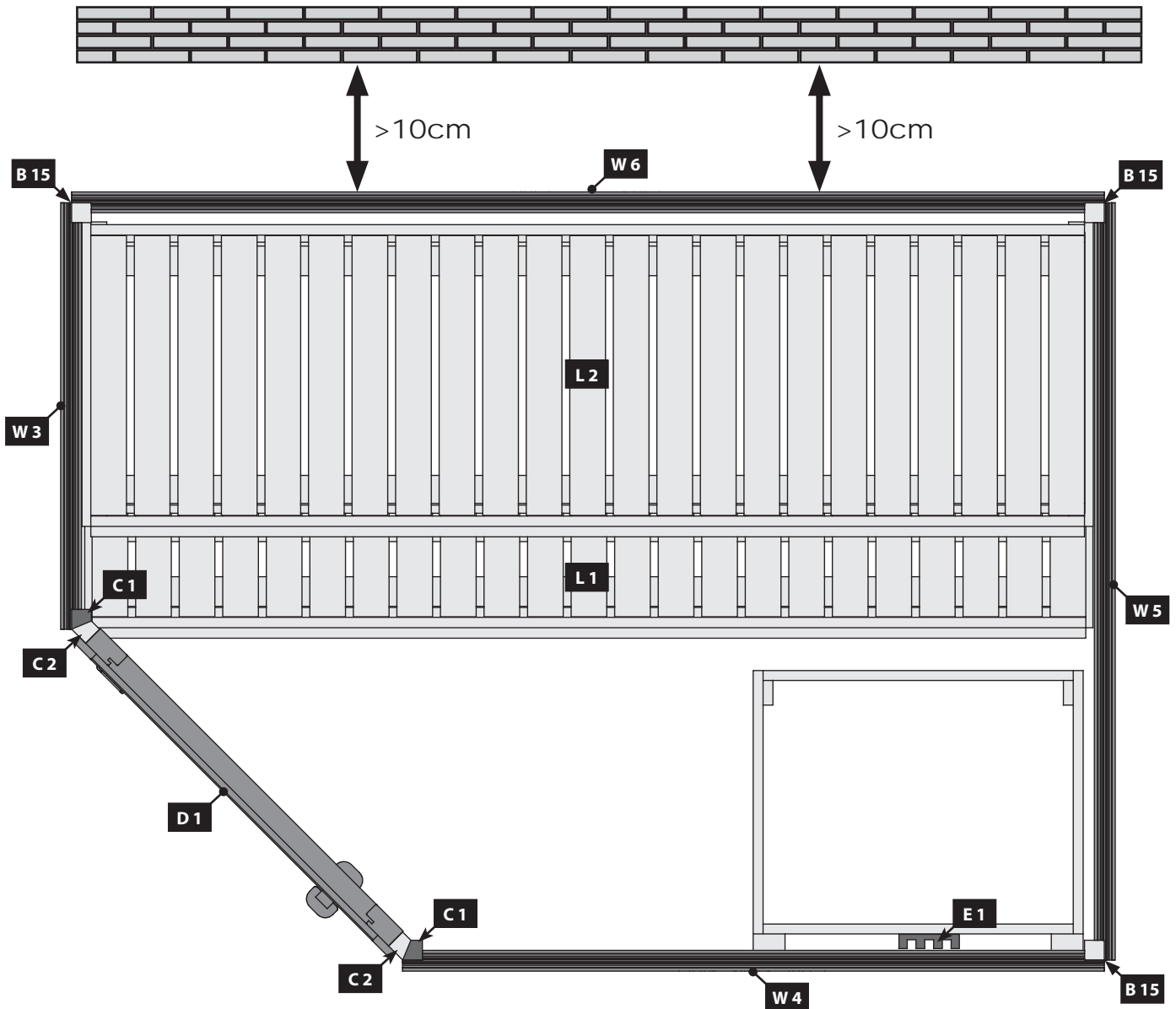

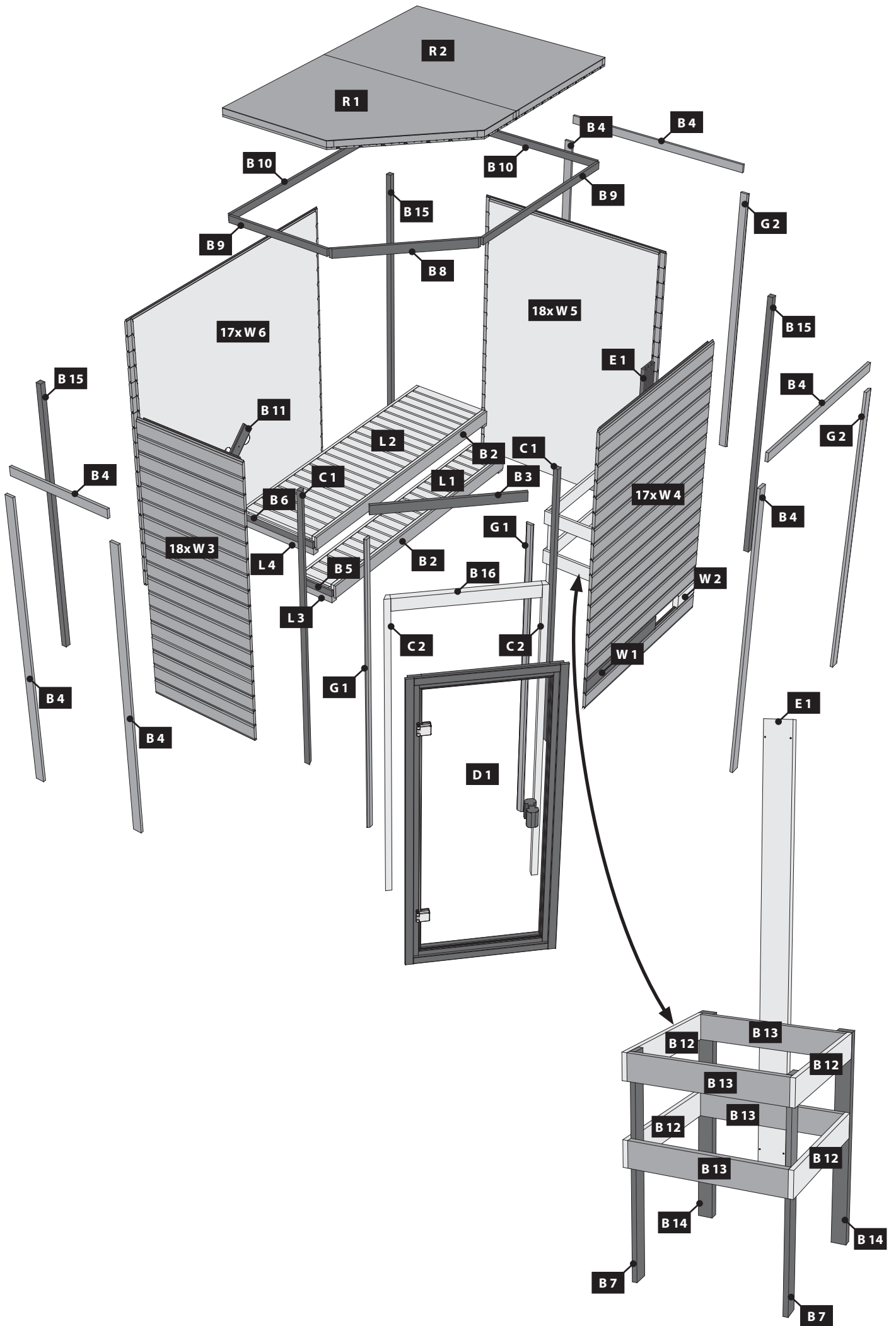
1 x		
-----	--	--



- Draufsicht
- vista desde arriba
- Top view
- vista desde arriba
- vue de dessus
- vista dall'alto
- bovenaanzicht
- púrdorys





 Achten Sie auf die gleiche Höhe
 Look for the same height
 Faites attention à la même hauteur

 Besteed aandacht aan de dezelfde hoogte
 Prestar atención a la misma altura
 Prestare attenzione alla stessa altezza

 Dávejte pozor na stejnou výšku
 Vær opmærksom på samme højde

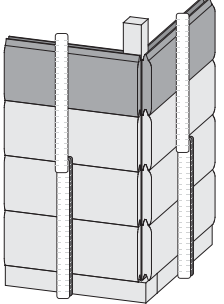
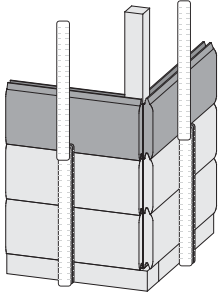
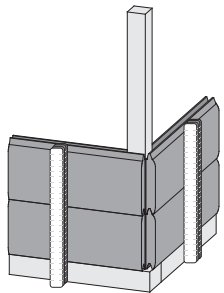

01

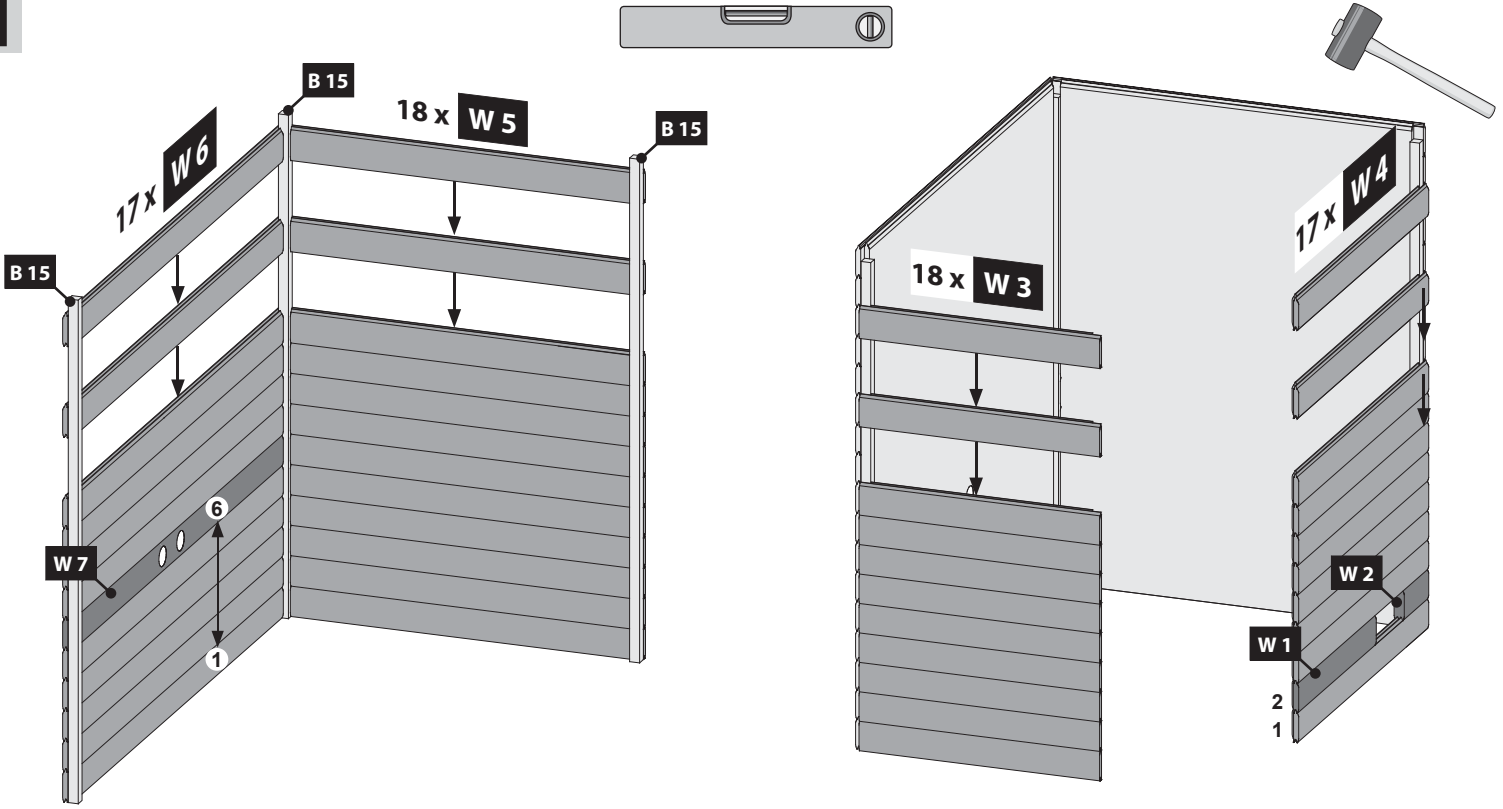

02

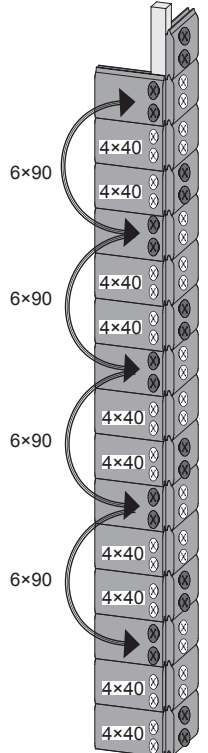
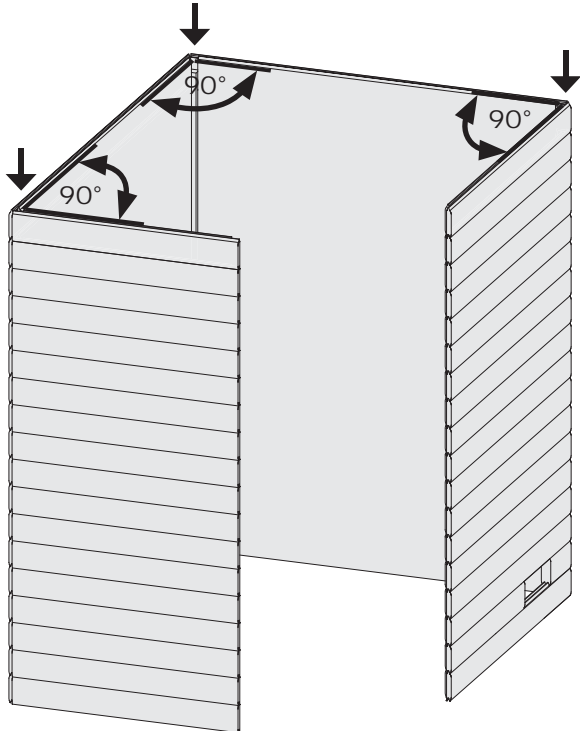
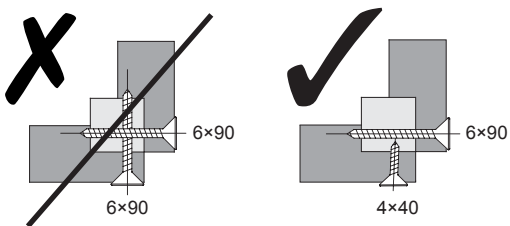

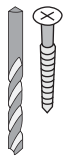
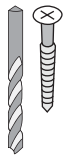
- 66x  Ø5 mm
- 138x  Ø3 mm

03

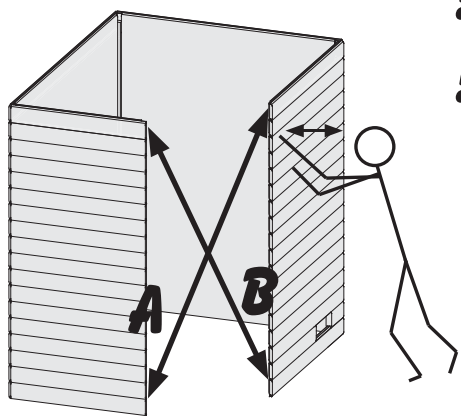

!!! A=B !!!
!!! C=D !!!

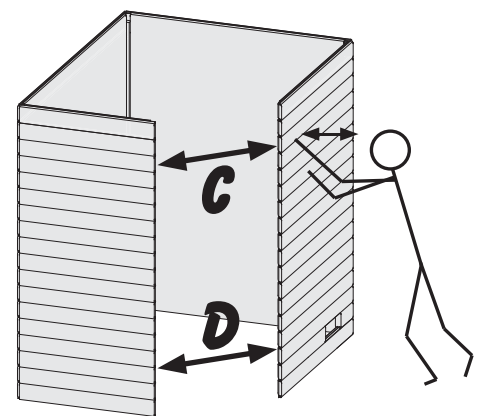

04

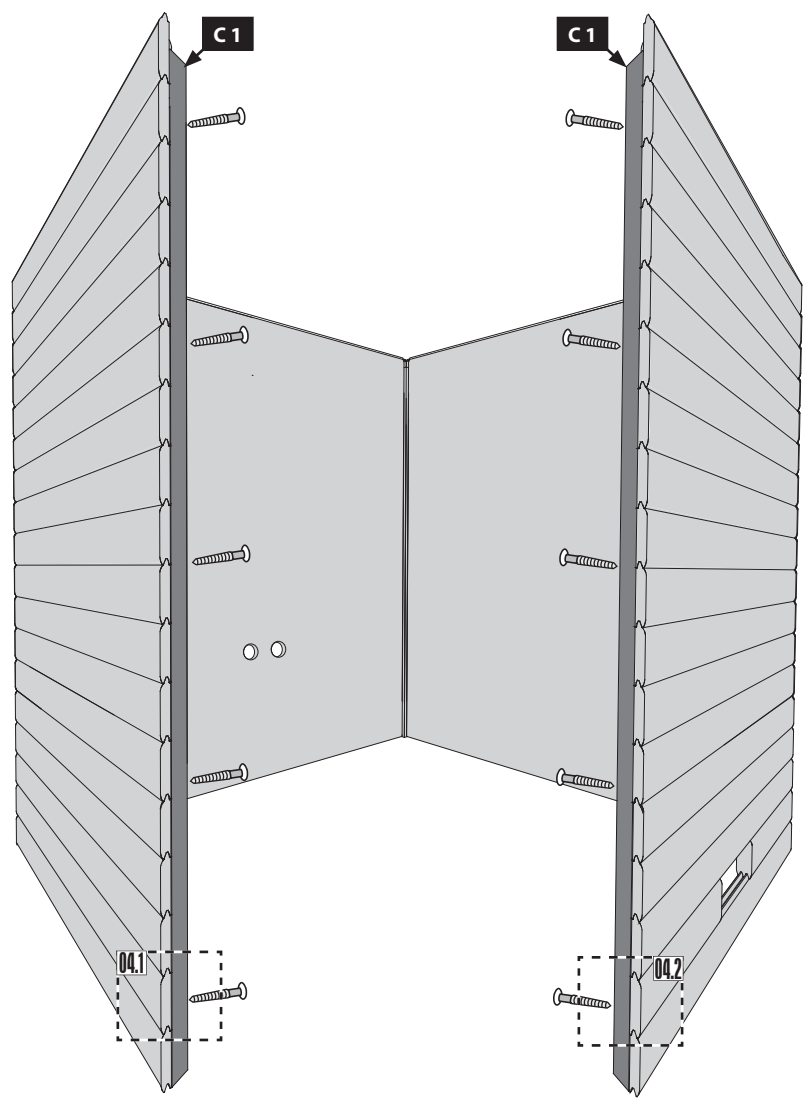

04.1

Ø3mm  4×50 

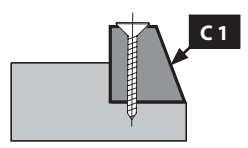
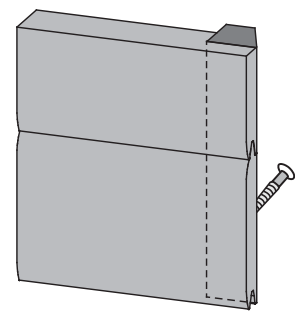

04.2

Ø3mm  4×50 

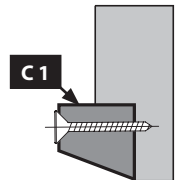
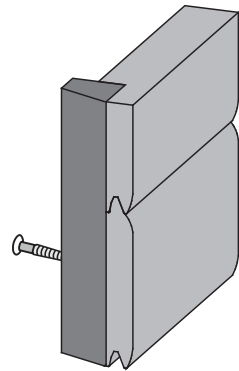

05

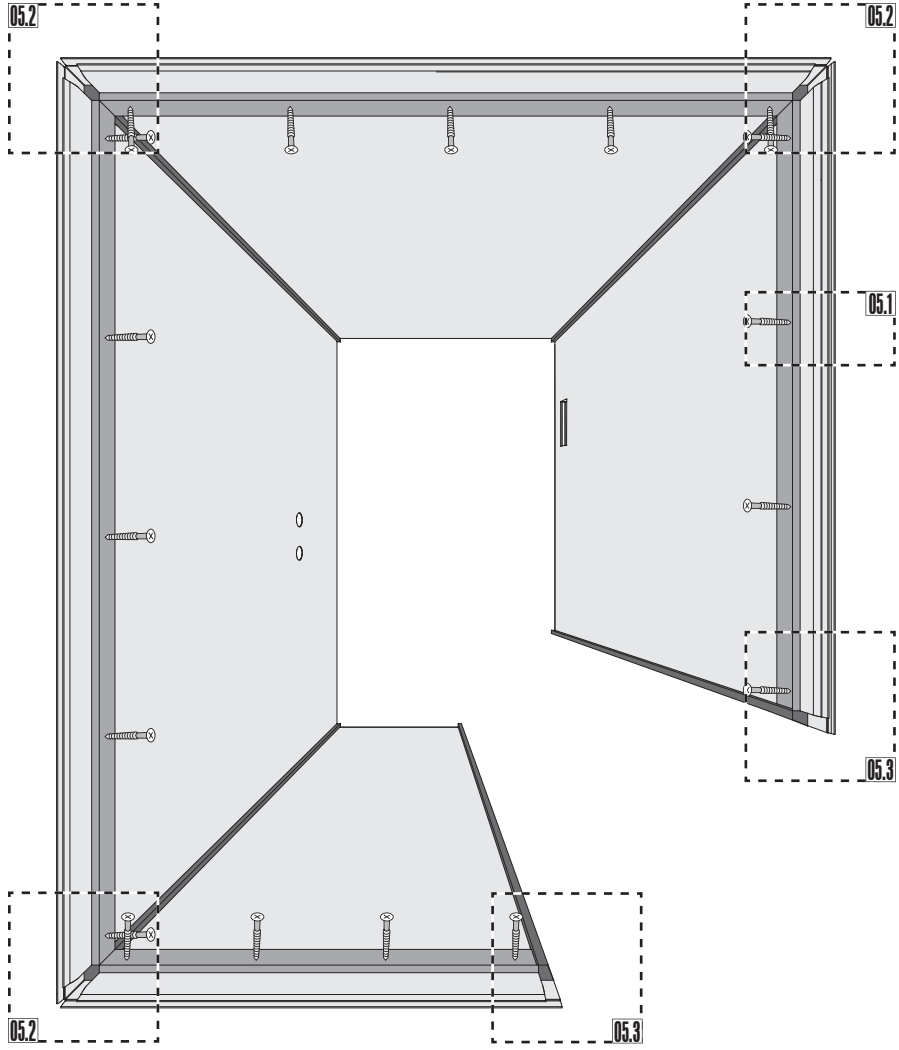
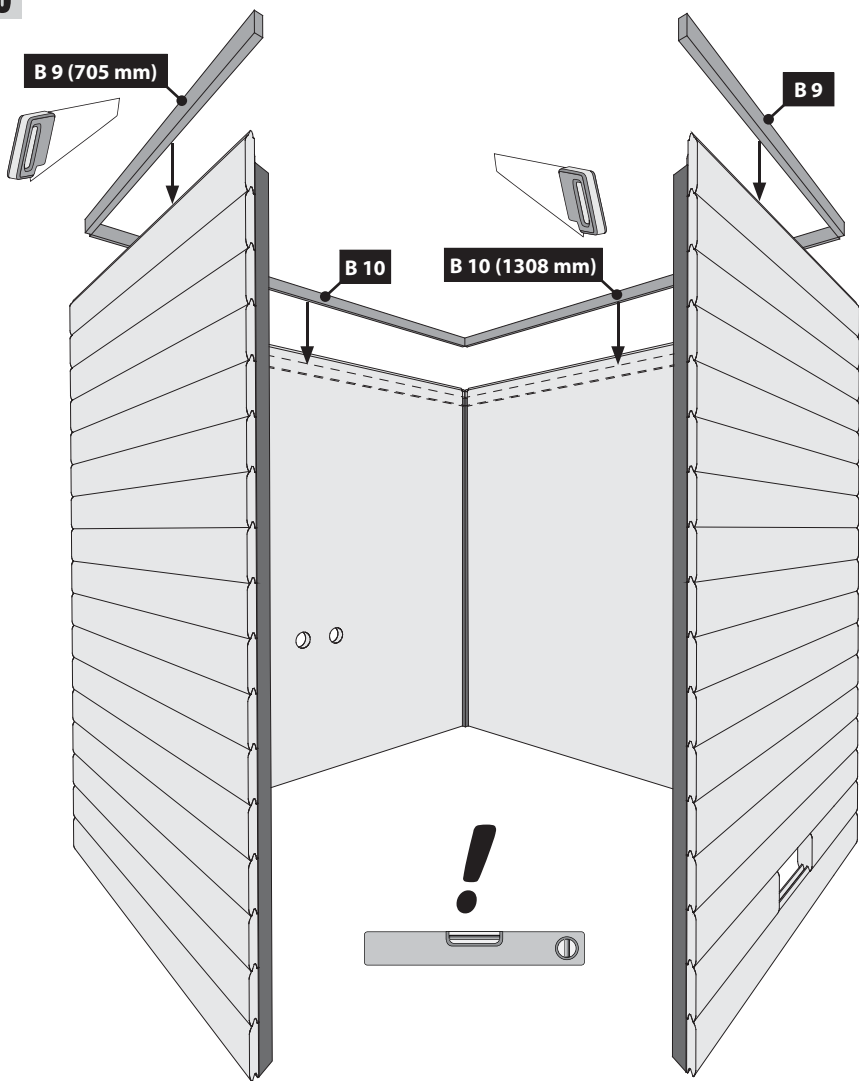

05.1

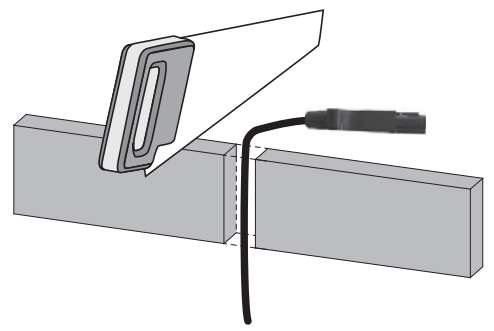

05.2

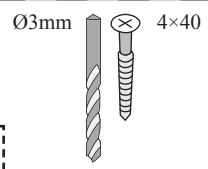

Bündig!
Affleurement!
Gelijk!
Aras!
Flush!
Combacia!
Stejný!

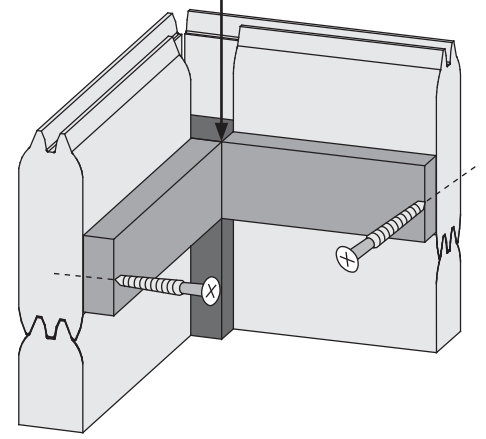

05.3

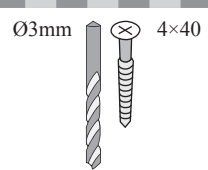

Bündig!
Affleurement!
Gelijk!
Aras!
Flush!
Combacia!
Stejný!

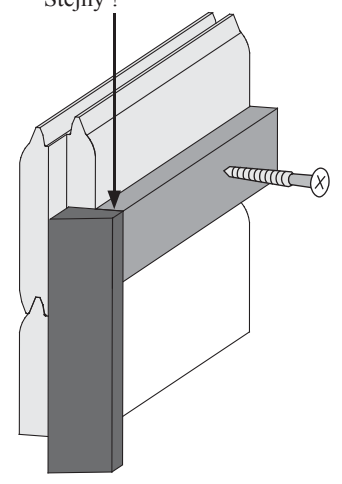

06

Ø3mm 4×50

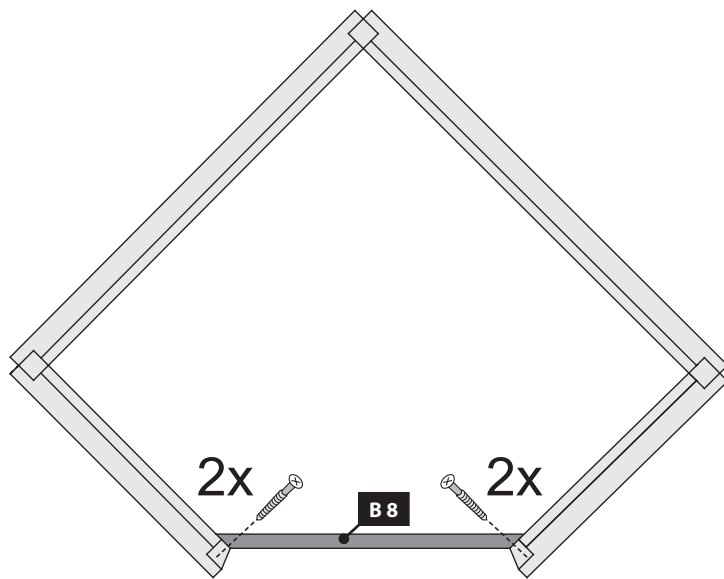
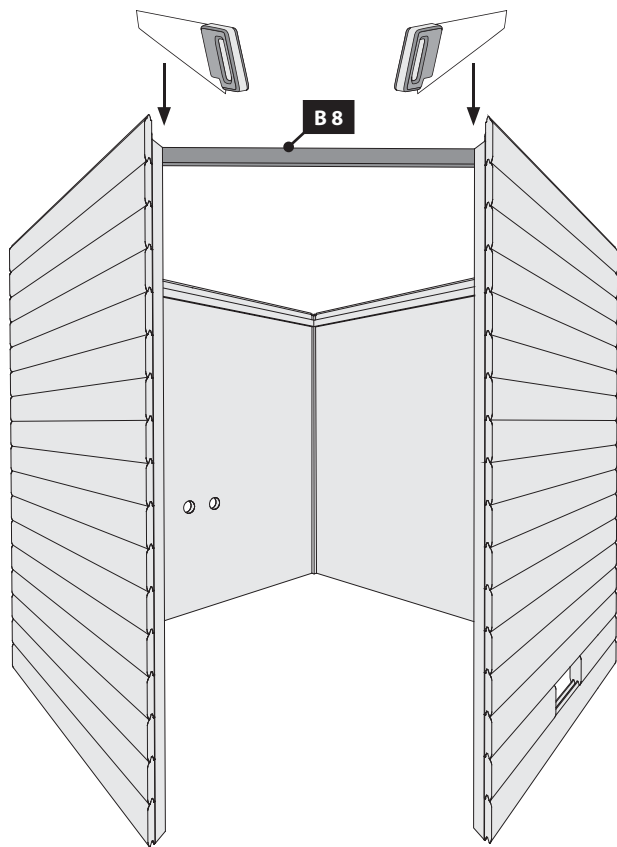



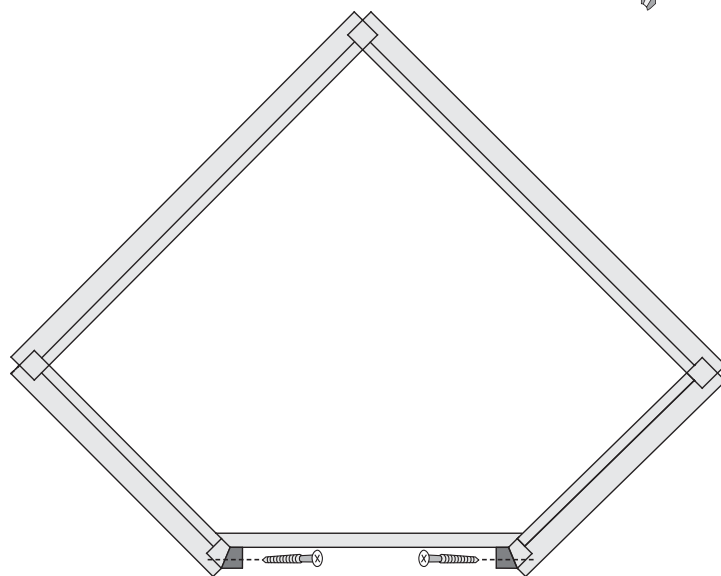
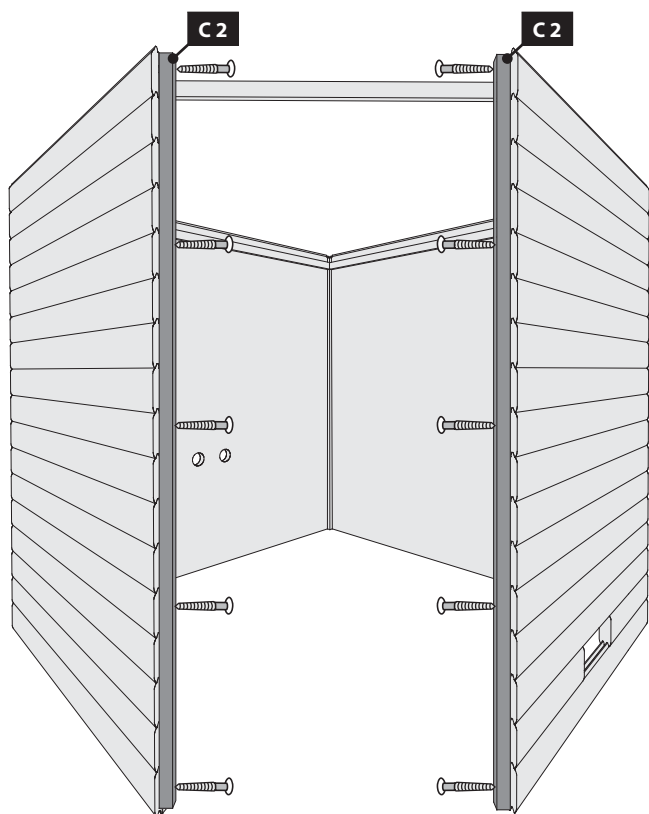

07

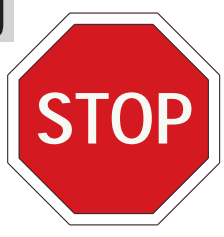
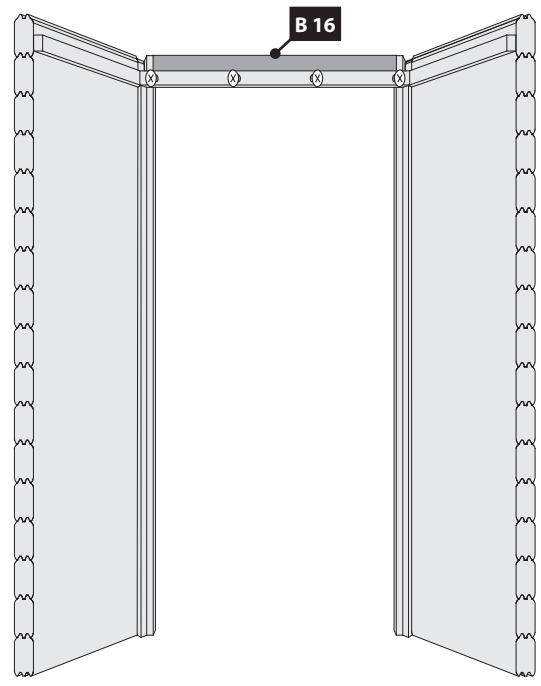
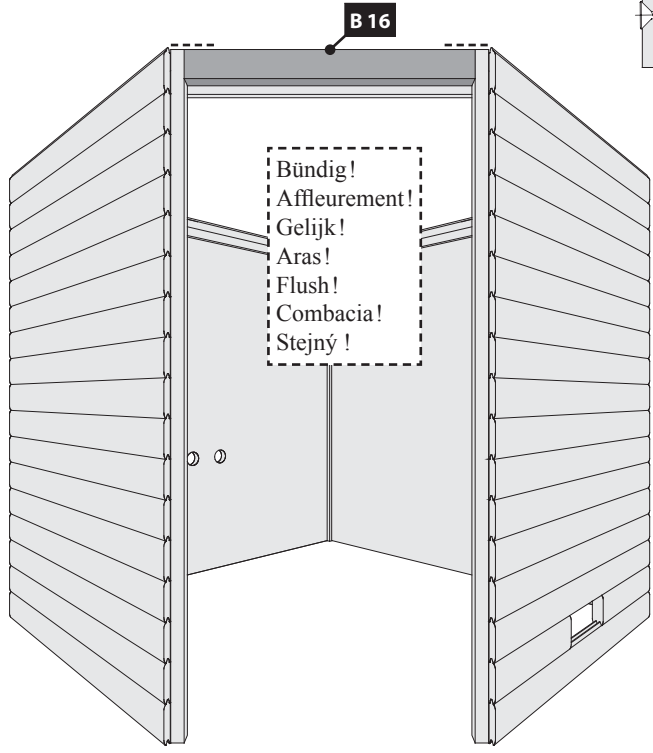
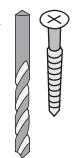
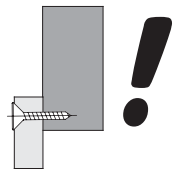

Ø3mm 4×50





-  Einbau Glastür
-  Montage porte en verre
-  Installation of glass door

-  Montage van de glazen deur
-  Montaje de la puerta de cristal

-  Installazione portello di vetro
-  Instalace skleněné dveře

!!! 01 – 03 !!!

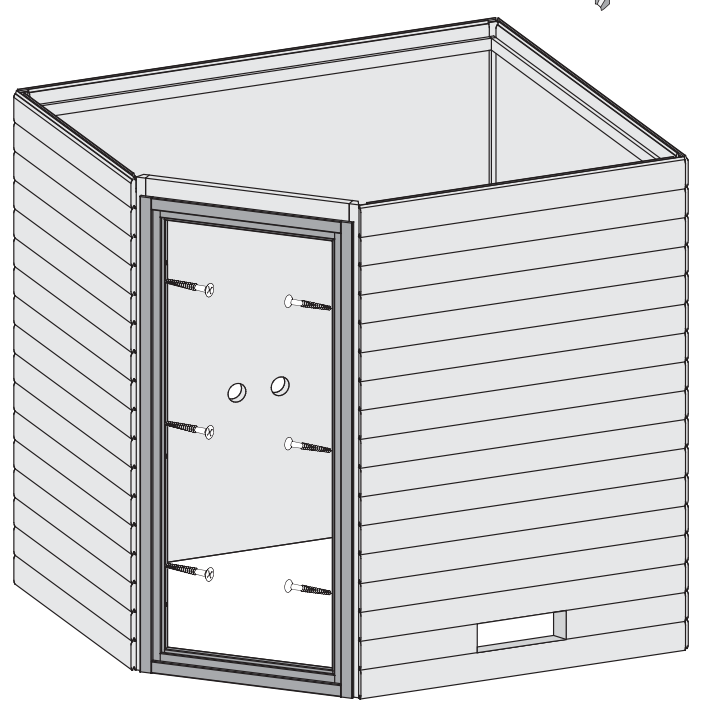
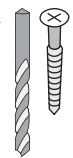
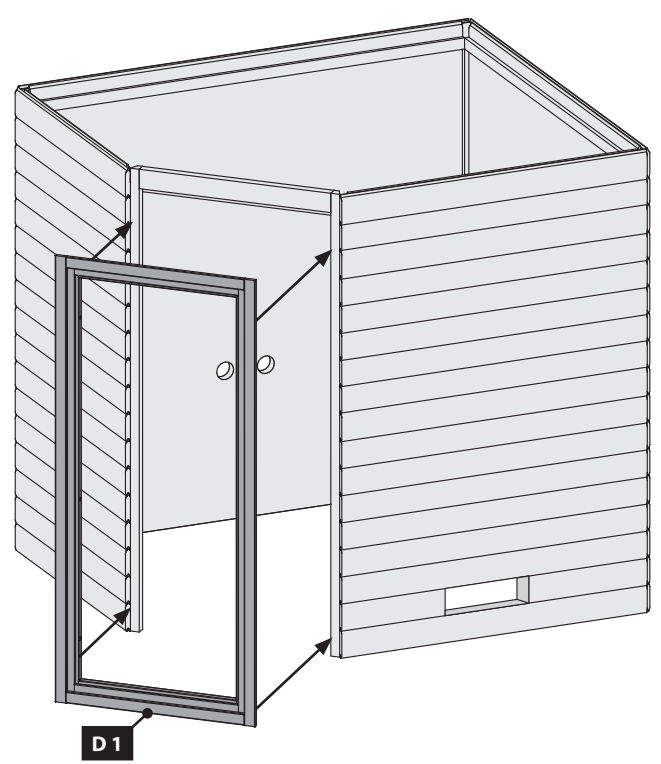

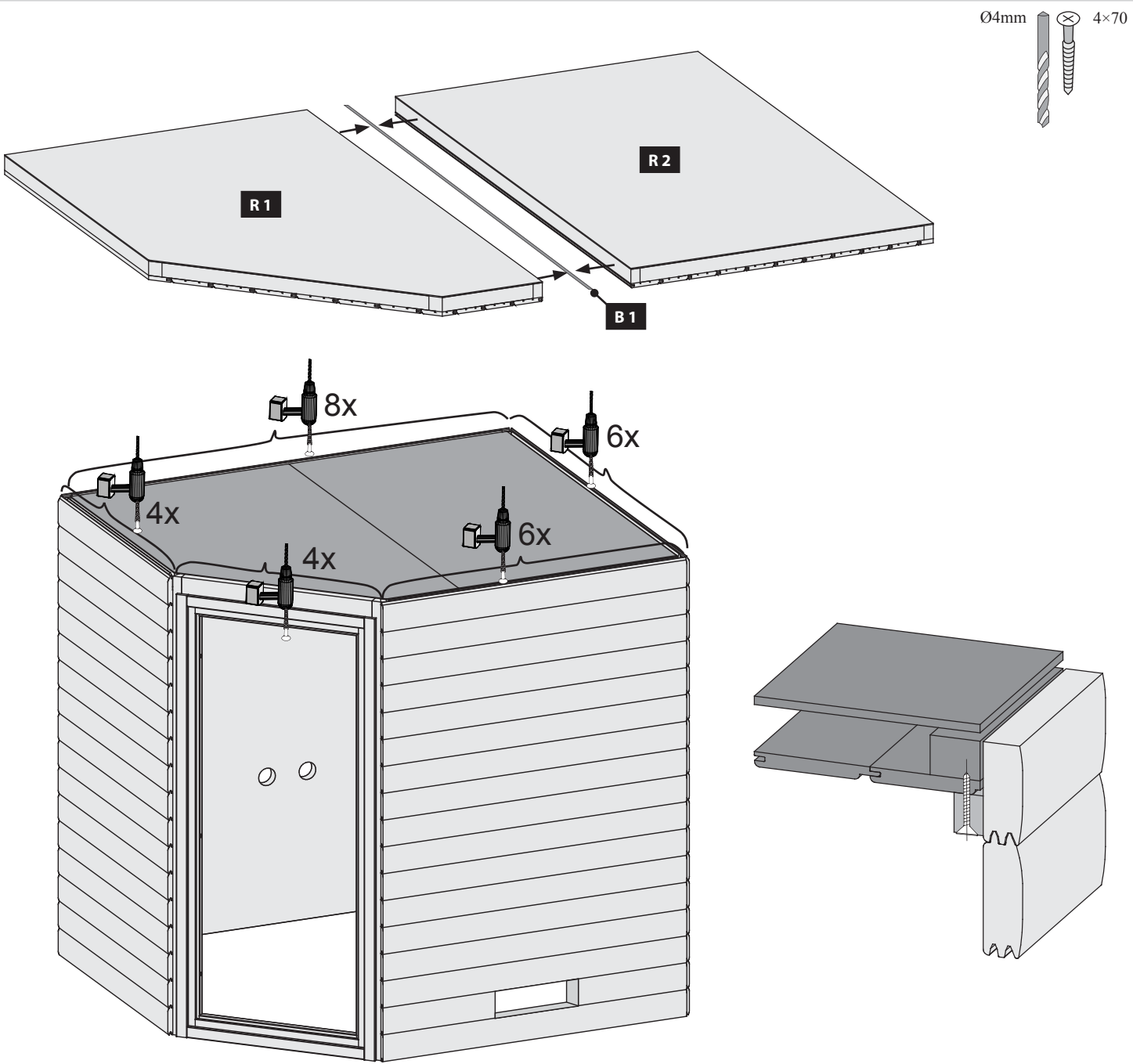
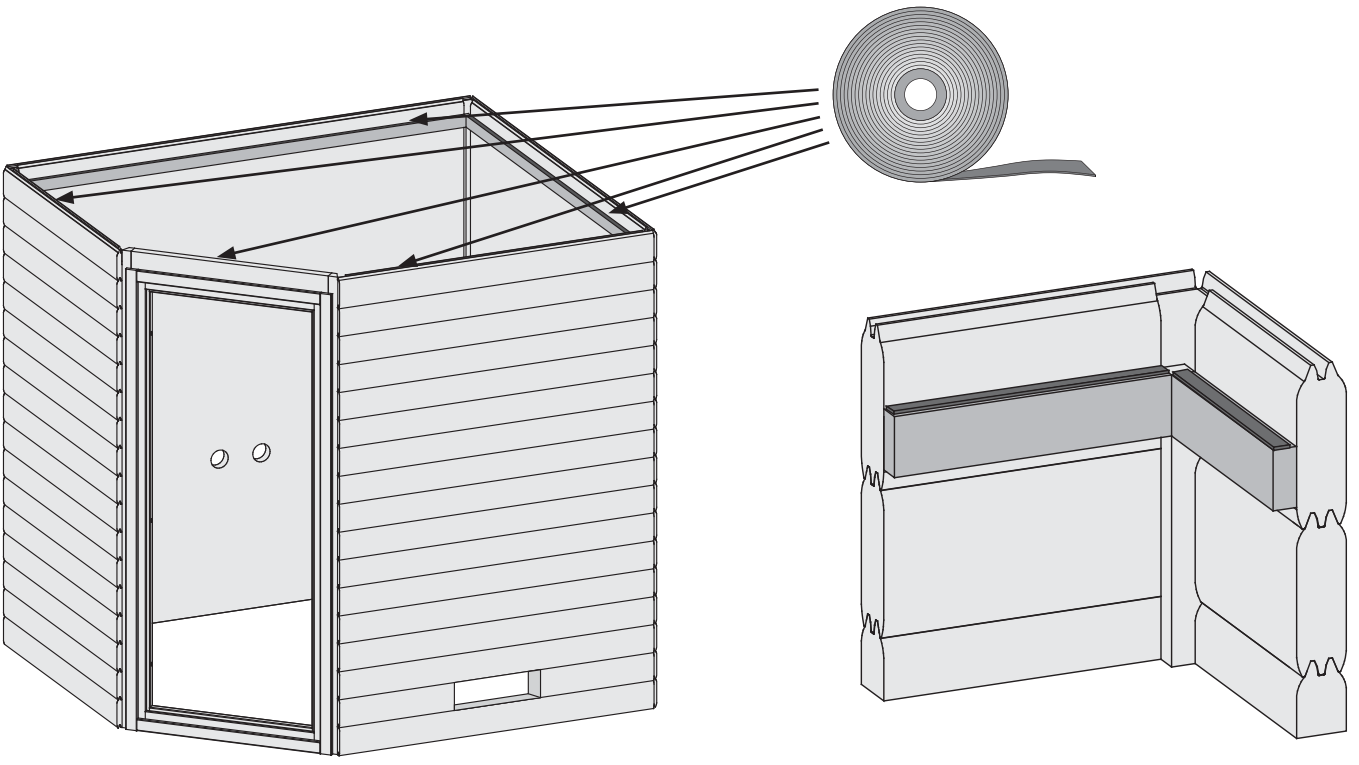

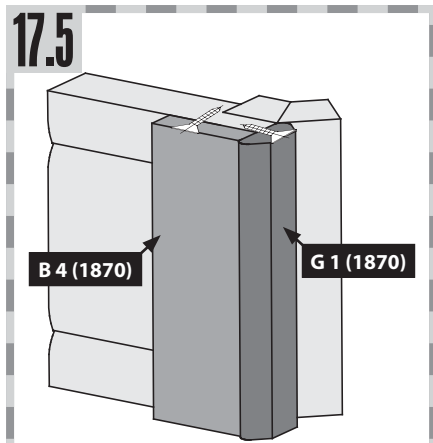
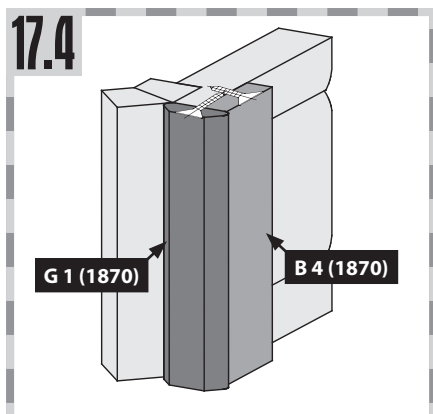
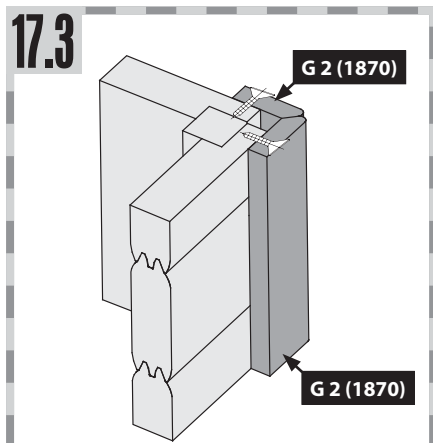
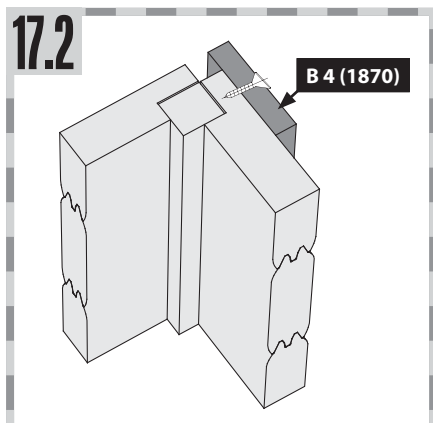
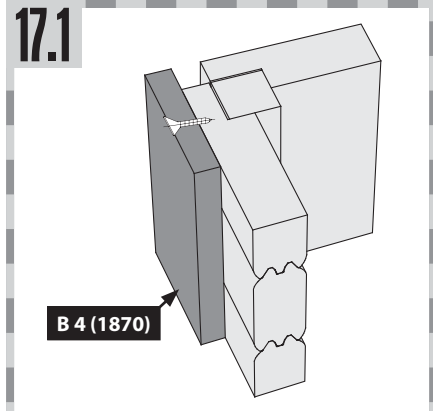
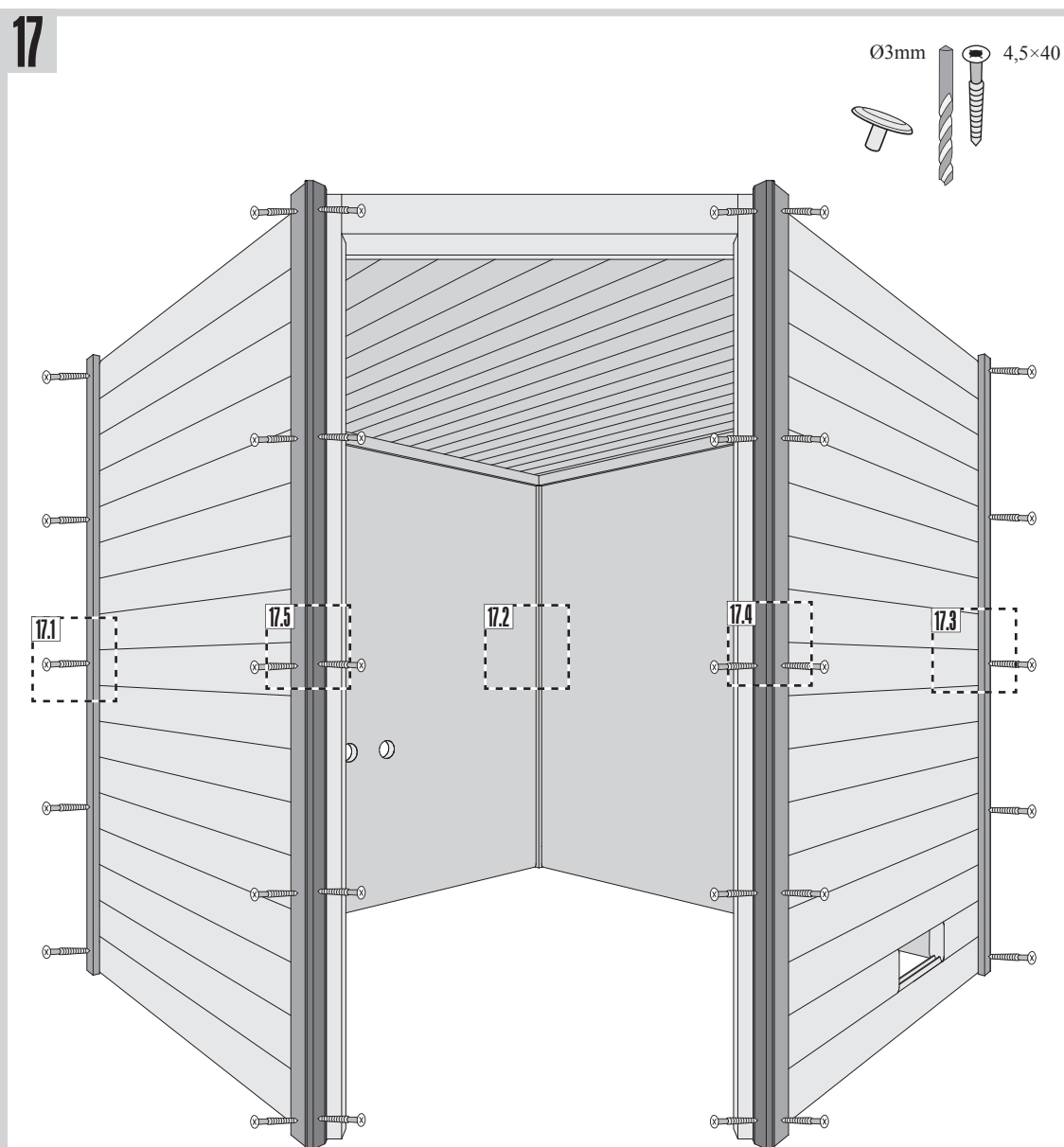
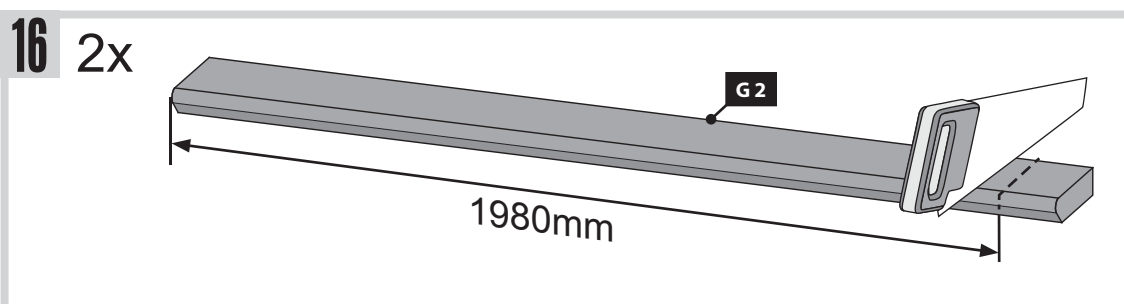
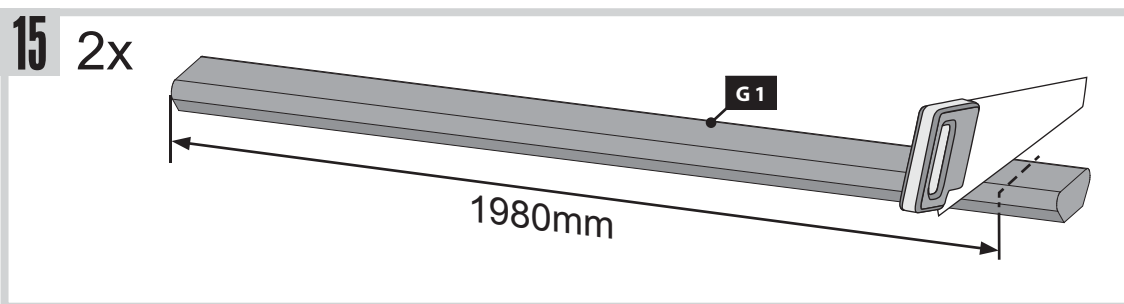
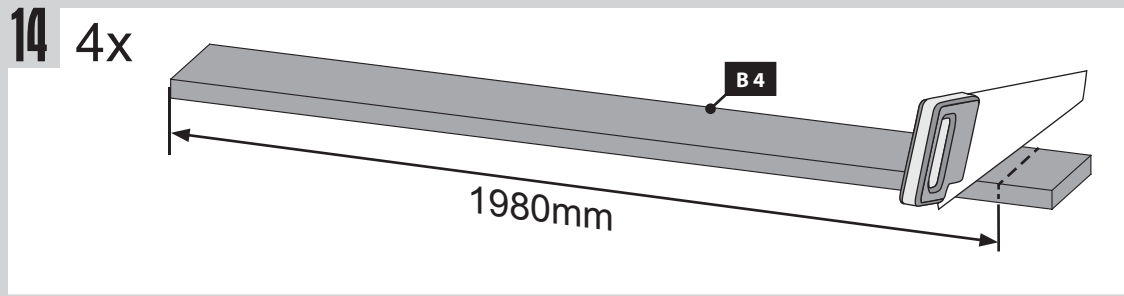

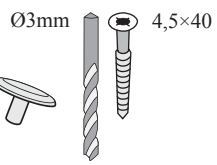

Bündig!
Affleurement!
Gelijk!
Aras!
Flush!
Combacia!
Stejný!

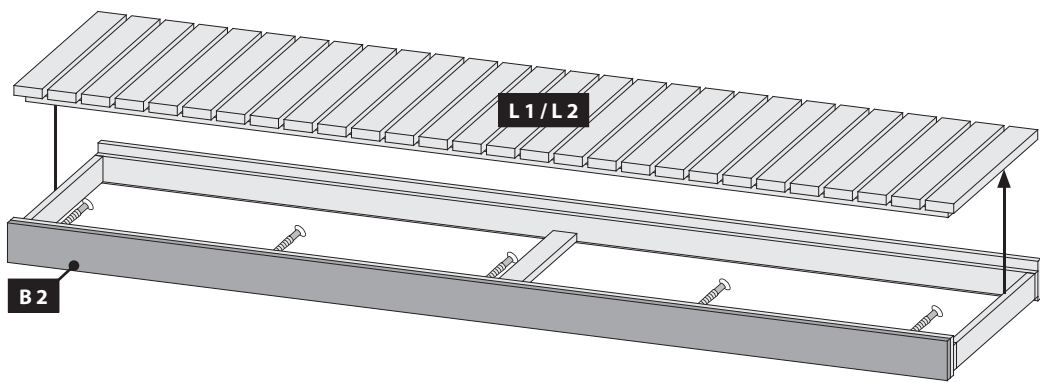
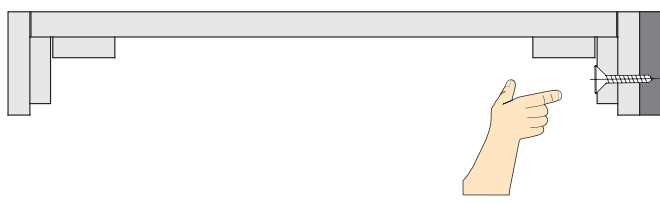
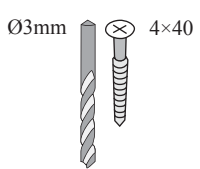
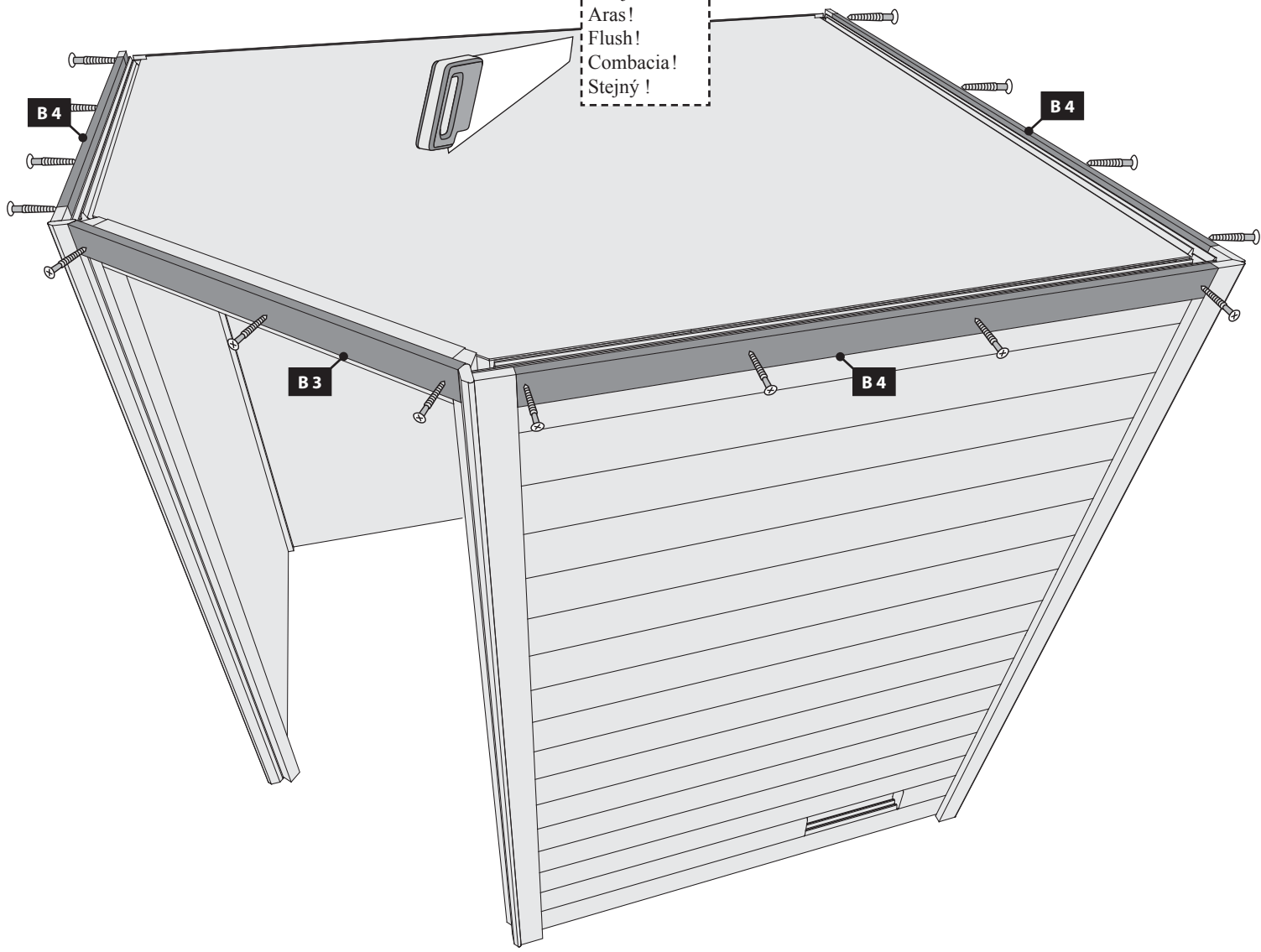

20 2x

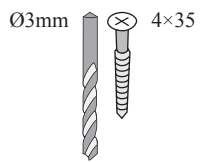
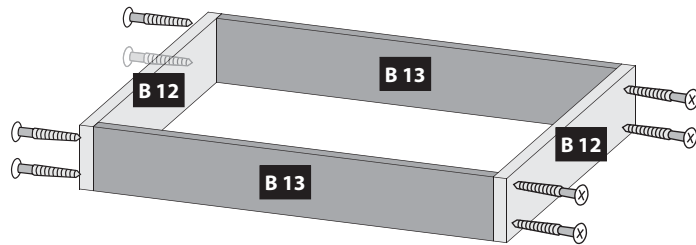

21 a

-  Nur bei 9 kW-Ofen
-  Seulement 9 kW chauffe
-  Only 9 kW heater
-  Slechts 9 kW heater
-  Sólo calentador de 9 kW
-  Solo riscaldamento 9 kW
-  Pouze topné těleso 9 kW

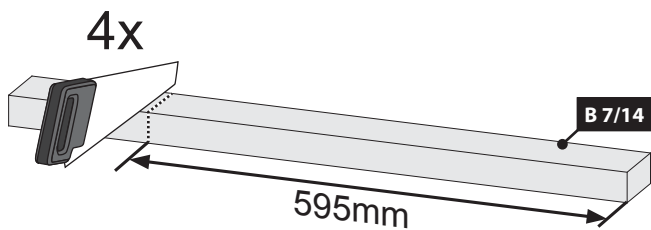
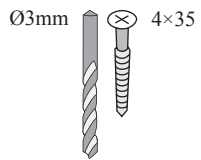
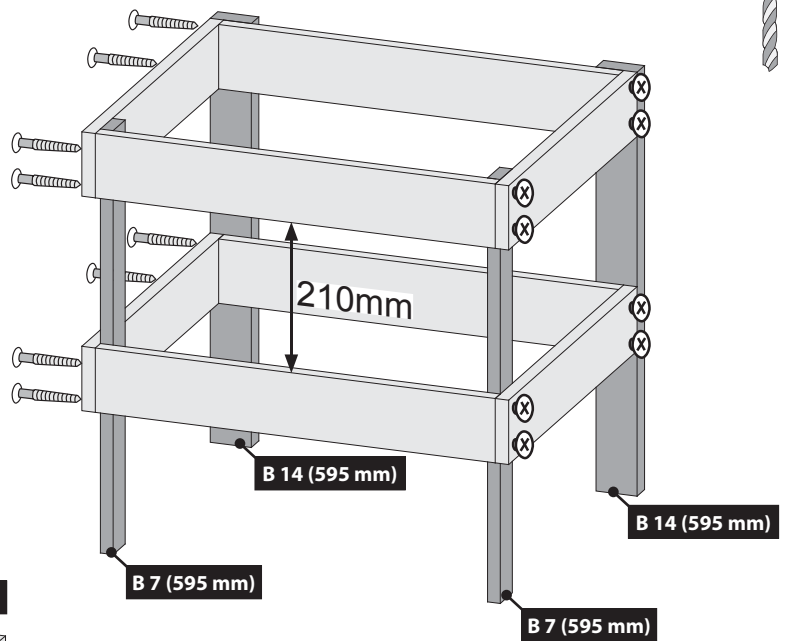

21 b

-  Bei allen anderen Öfen
-  Pour tous les autres fours
-  For all other furnaces
-  Voor alle andere ovens
-  Para todos los otros hornos
-  Per tutti gli altri tipi di forni
-  U všech ostatních pecích

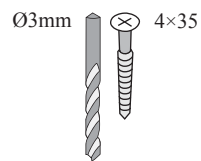
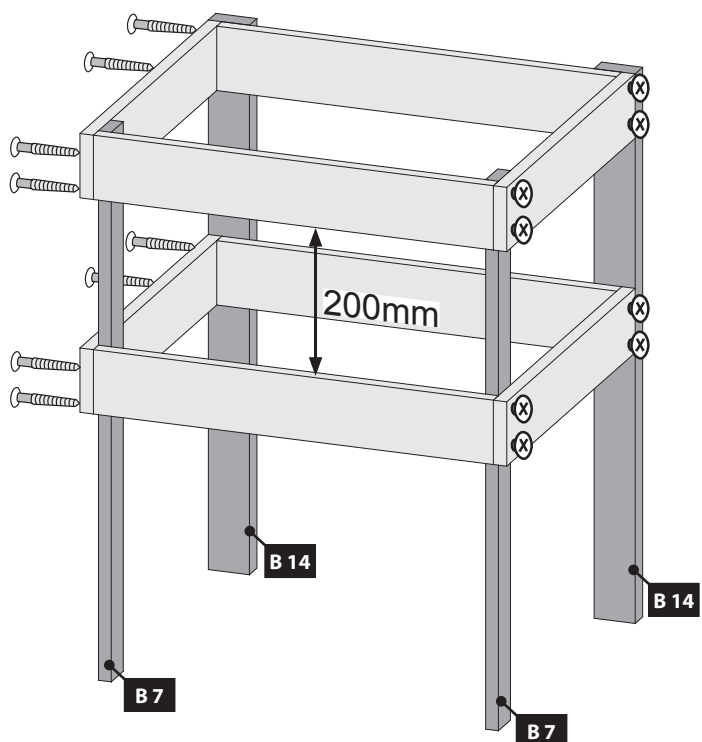

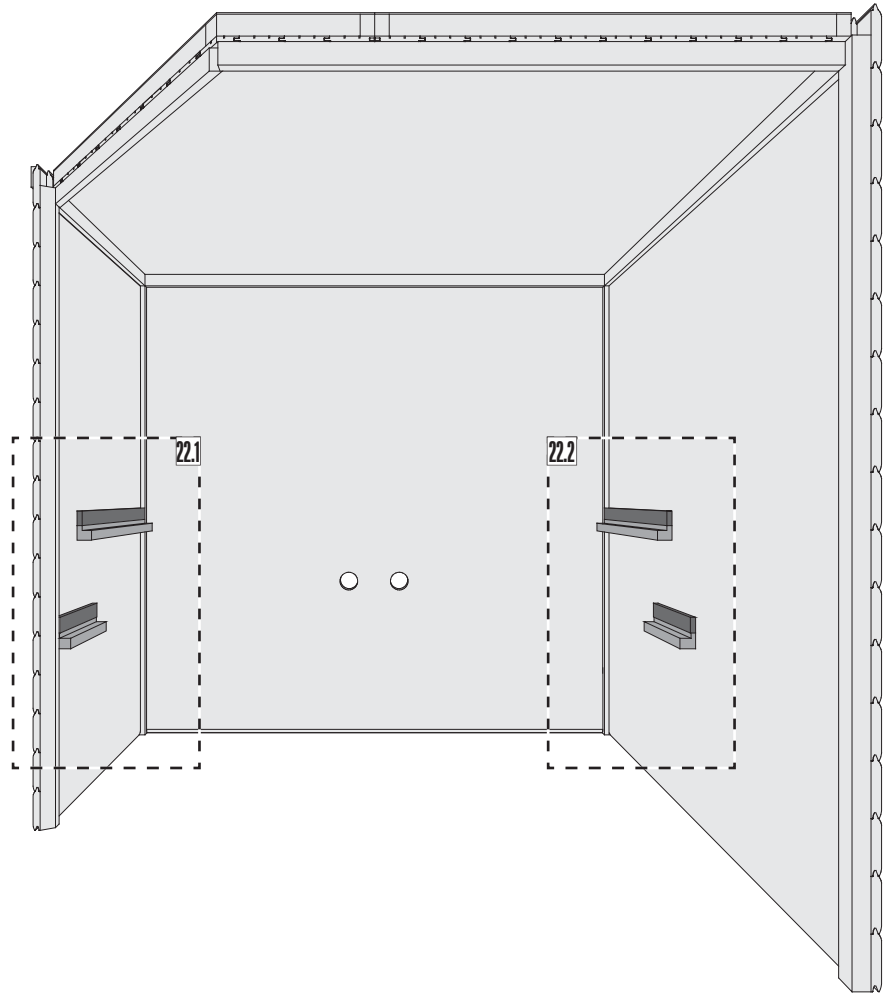

22.1-1

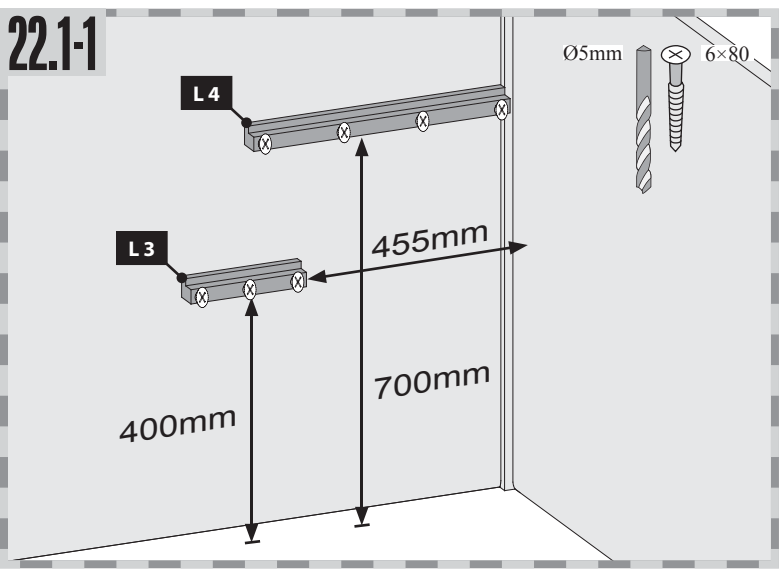

22.2-1

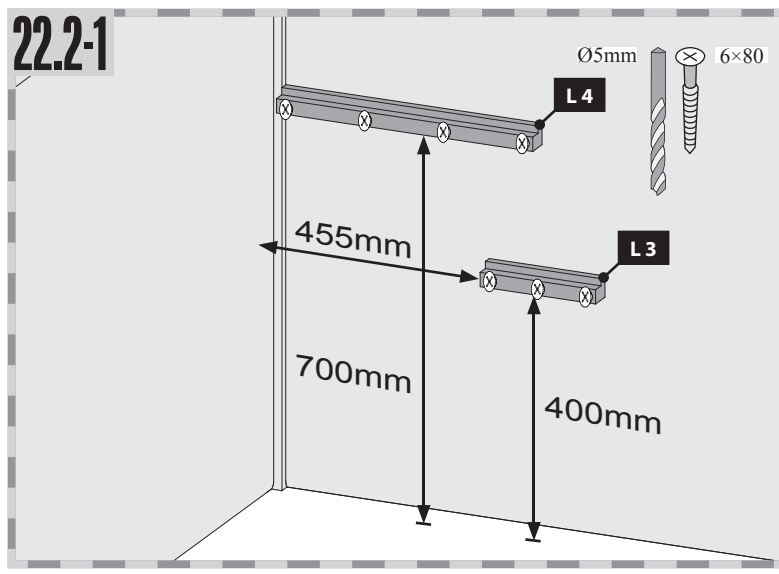

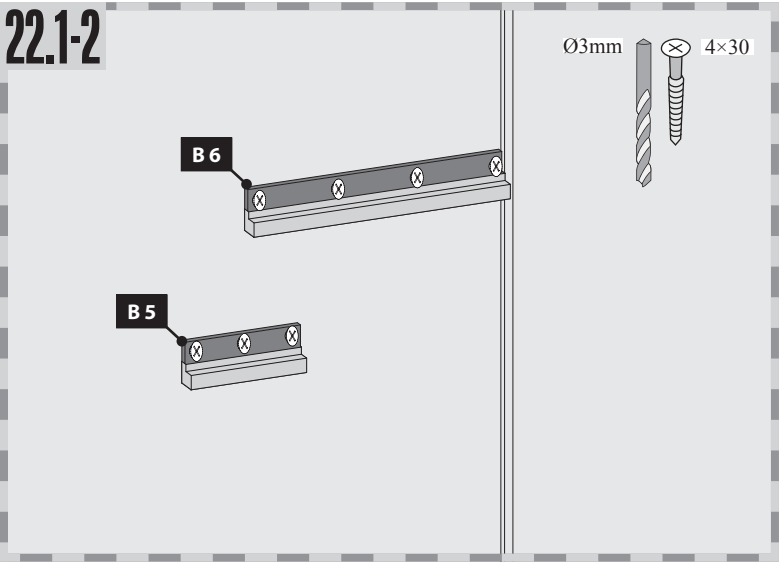

22.1-2



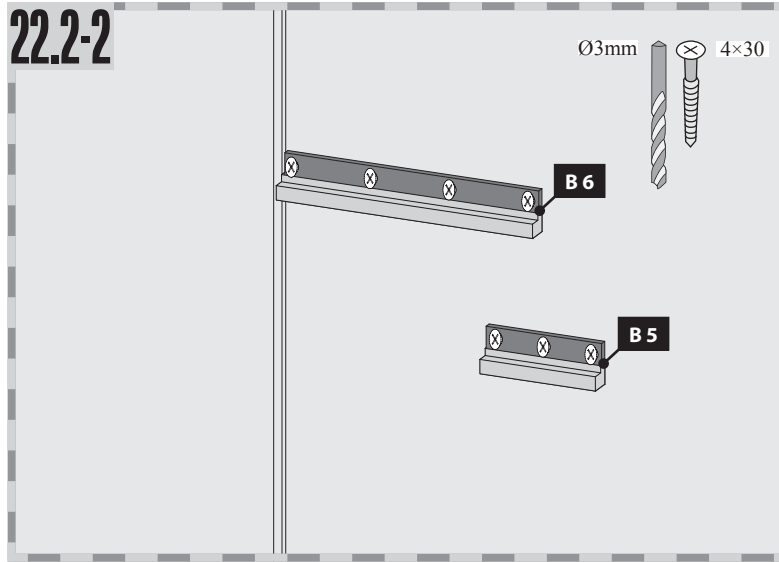

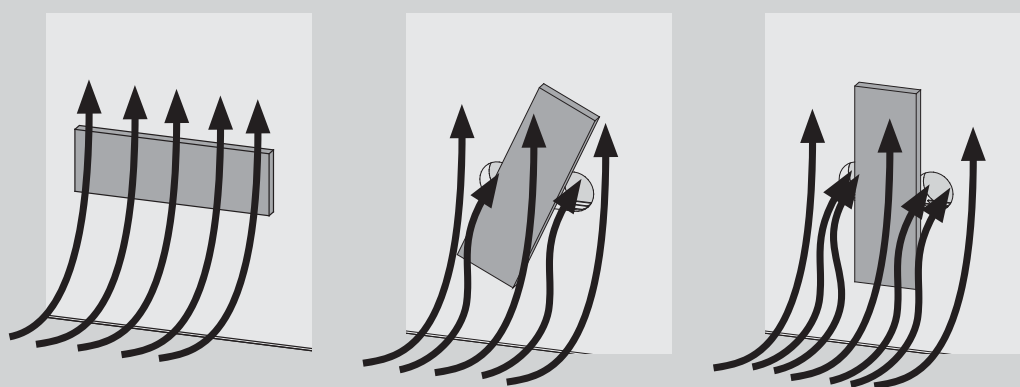
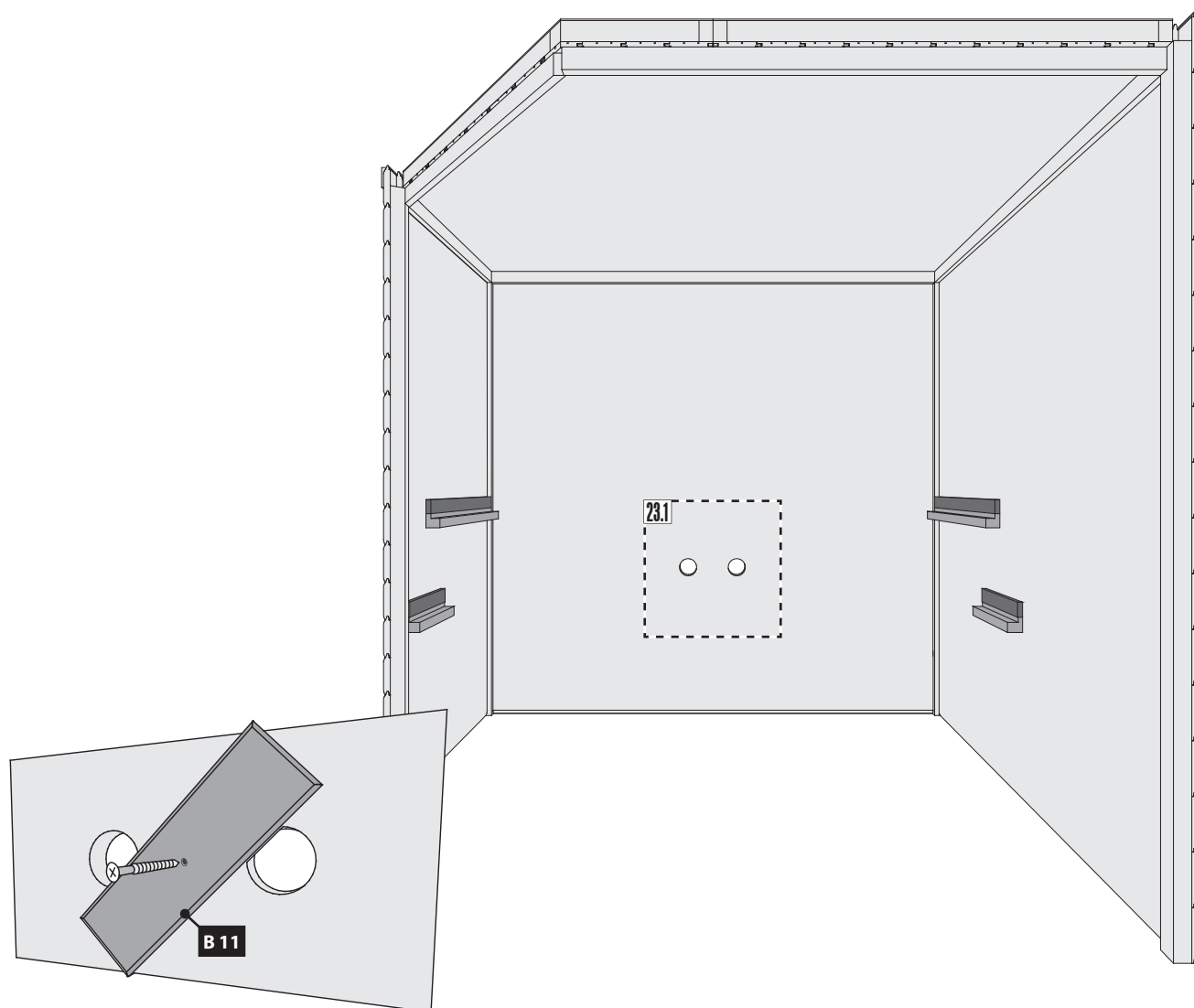
22.2-2







 Hier ist die Funktionsweise des Brettes abgebildet. Regeln Sie damit die Abluft nach Ihren eigenen Wünschen.

 Ceci représente le mode de fonctionnement de la planche. Avec elle, réglez l'écoulement de l'air selon vos désirs.

 This figure shows the functional principle of the board. Regulate the exhaust air according to your own wishes.

 Hier is de werking van het plankje afgebeeld. Regel daarmee de luchtafvoer naar eigen wens.

 Aquí está representada la forma de funcionamiento de la tabla. Regule con ello el aire de salida según sus propios deseos.

 Viene illustrato il principio di funzionamento della tavoletta di regolazione della ventilazione. Con essa si può regolare a piacere la ventilazione.

 Zde je zobrazená funkce desky. Regulujte s ní odsávací vzduch dle Vašeho přání.

24

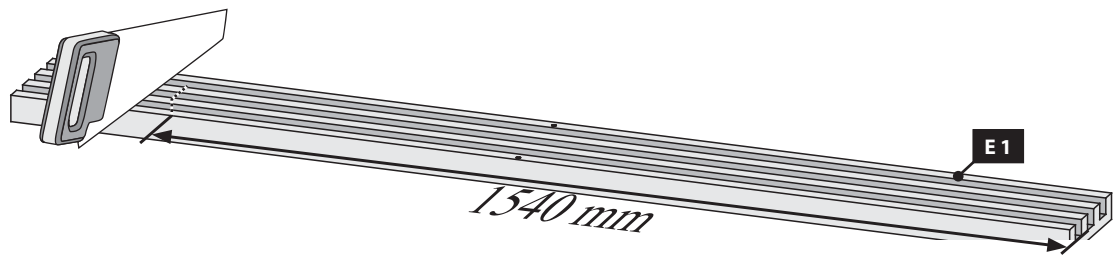

25

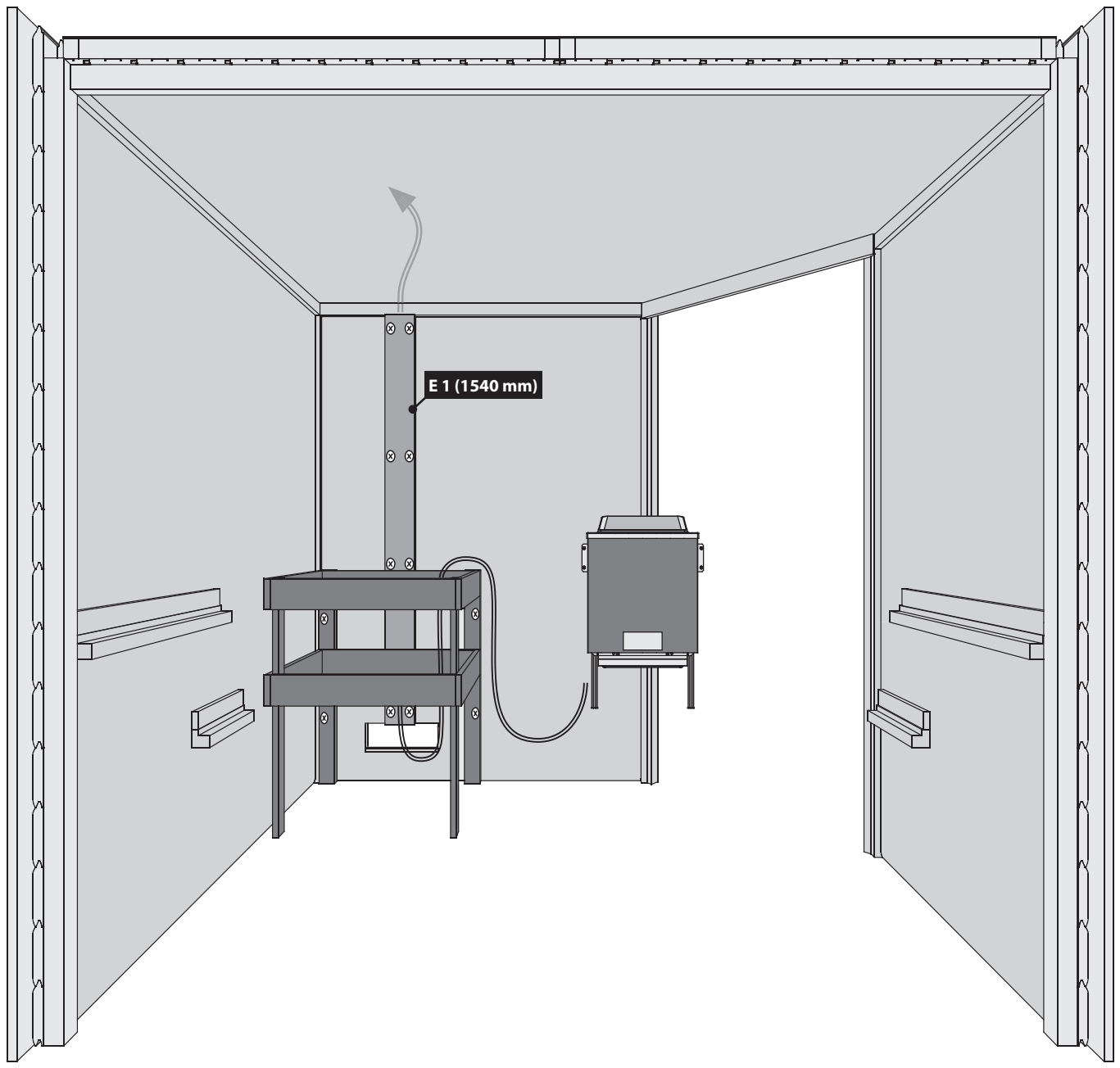
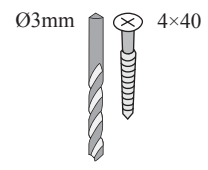

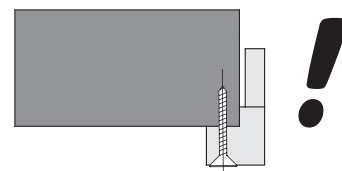
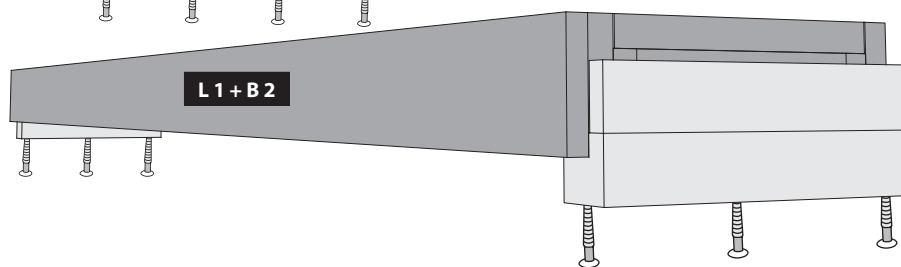
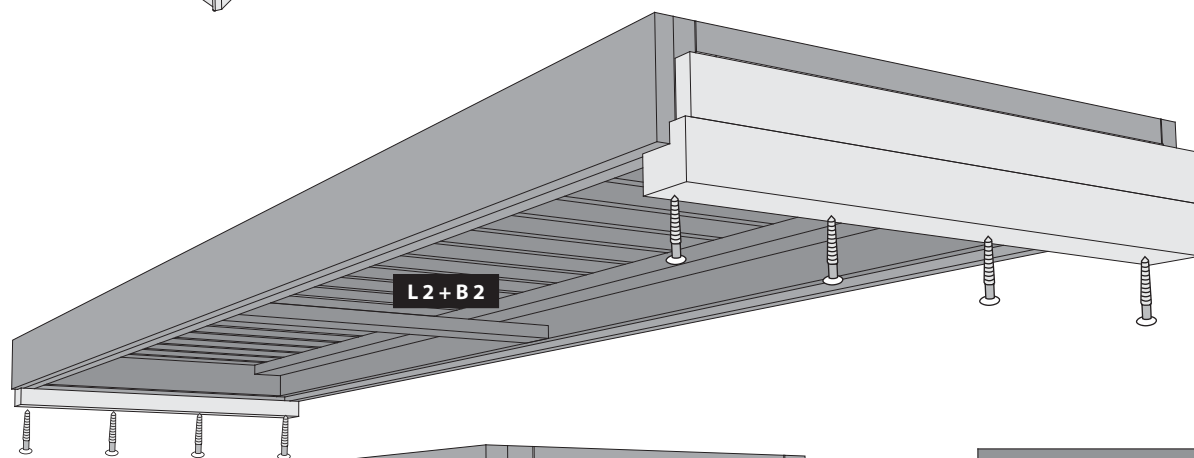
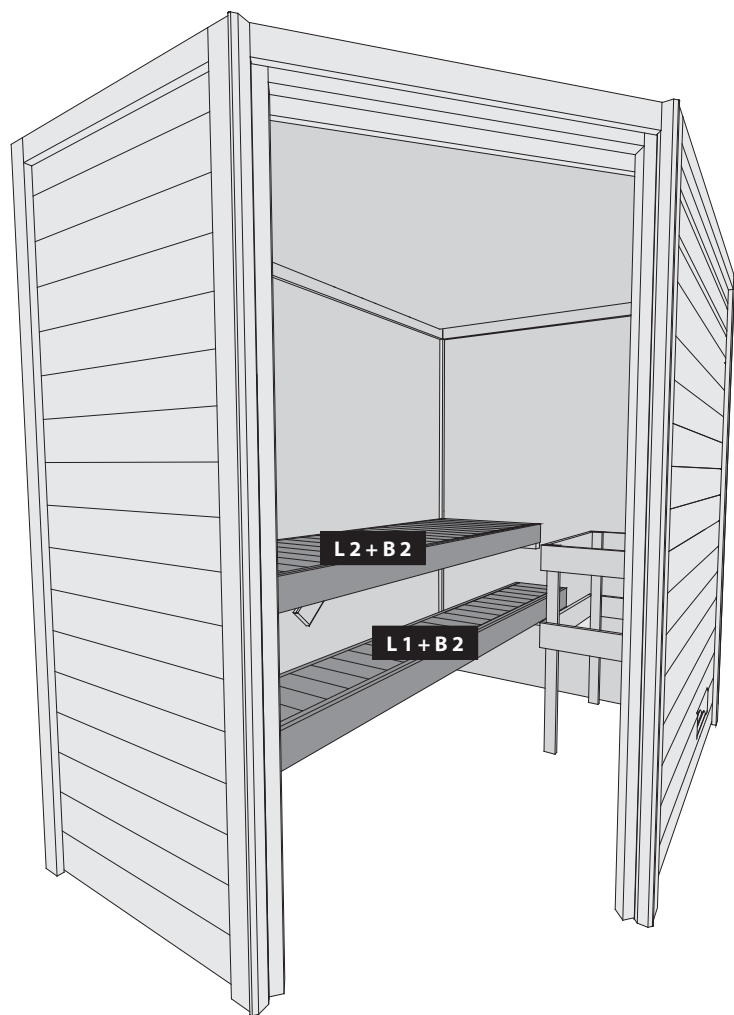
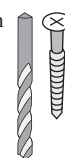

04 — 08



 Einbau Glastür

 Montage porte en verre

 Installation of glass door

 Montage van de glazen deur

 Montaje de la puerta de cristal

 Installazione portello di vetro

 Instalace skleněné dveře

 Installation TÜV-Schild

 Installatie TÜV Shield

 Instalace TÜV Shield

 Installation TÜV Shield

 Installazione TÜV Shield

 Namestitev TÜV tablice

 Installation TÜV Shield

 Instalación TÜV Escudo

01

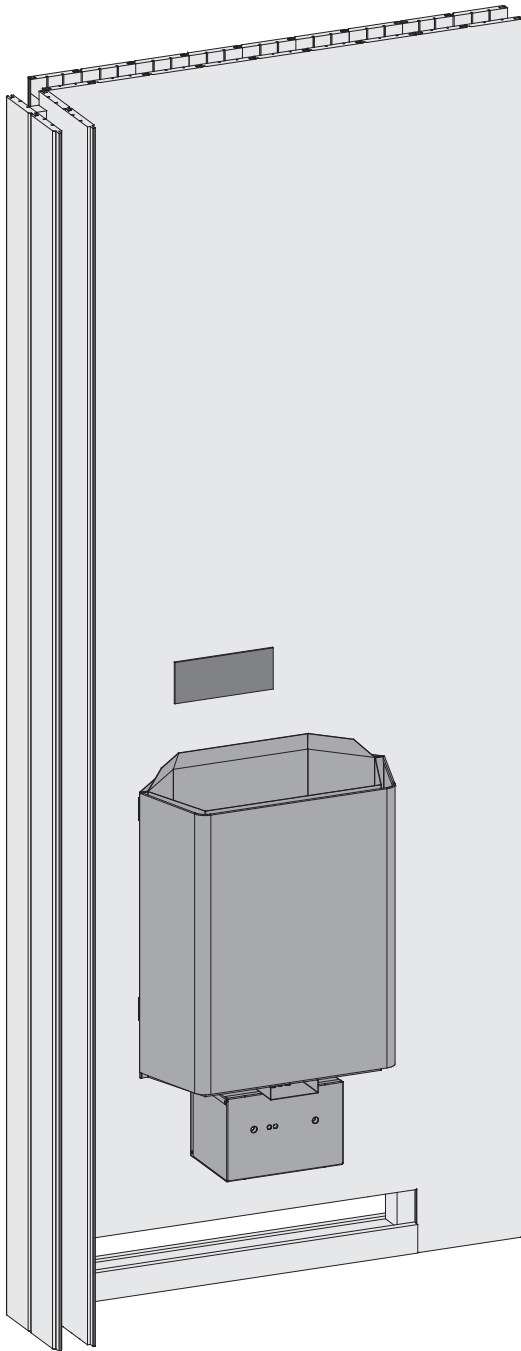



 Entfernen Sie die Schutzfolie vom beiliegenden TÜV-Schild. Lassen Sie den Saunaofen von einem zugelassenen Elektrofachmann anschließen. Dieser markiert den installierten Ofen auf dem TÜV-Schild. Bringen Sie das TÜV-Schild an einer gut sichtbaren Stelle über dem Ofen an.

 Remove the protective film from the accompanying Participate Schild. Lassen connecting the heater by a licensed electrician. This marks the installed furnace on the TÜV sign. Attach the TÜV sign at a conspicuous place on the stove.

 Retirez le film protecteur de l'accompagnant Participer Schild. Lassen raccorder l'appareil par un électricien agréé. Ceci marque le four installé sur le signe TÜV. Fixer le signe de TÜV à un endroit bien en vue sur le poêle.

 Verwijder de beschermfolie van de begeleidende Deelnemen Schild. Lassen het aansluiten van de kachel, door een erkende elektricien. Dit markeert de geïnstalleerde oven op het TÜV teken. Bevestig de TÜV teken op een opvallende plaats op het fornuis.

 Rimuovere la pellicola protettiva dal accompagna Partecipa Schild. Lassen collegando il riscaldatore da un elettricista qualificato. Questo segna il forno installato sul segno TÜV. Fissare il segno TÜV in un luogo ben visibile sulla stufa.

 Retire la película protectora de la Schild. Lassen acompaña Participar conectar el calentador por un electricista autorizado. Esto marca el horno instalado en el signo TÜV. Coloque el cartel de TÜV en un lugar visible en la estufa.

02

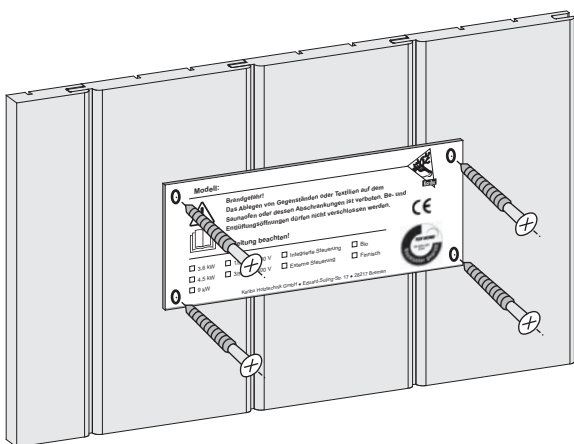

 Odstraňte ochrannou fólii z doprovodného Hlavní Schild. Lassen připojení ohříváče licencovaným elektrikář. Toto označí Instalovaný pec na znamení TÜV. Připevněte znamení TÜV na dobře viditelném místě na sporáku.

 S priložene tablice odstranite zaščitno folijo. Peč savne naj priključi usposobljeno osebnje, ki inštalirano peč označi na TÜV tablici. Tablico namestite na vidno mesto peči.

